

Hybrid Electric Vehicle Torque Distribution Control Method and System with Environmental Temperature Protection Battery Integration

¹Sai Krishnan Ganesh, ²Nagarajan Krishnamurthy

¹Department of Mechanical Engineering, Rajalakshmi Institute of Technology, Chennai, Tamilnadu

²Department of Computer Science and Engineering, Rajalakshmi Institute of Technology, Chennai, Tamilnadu

saikrishnan.g@ritchennai.edu.in, nagarajan.p.k@ritchennai.edu.in

Abstract

This research presents a hybrid electric vehicle (HEV) torque distribution control method and system that incorporates an environmental temperature protection battery. The study involves the collection of ambient temperature information to determine the vehicle's location and utilizes a battery equivalent circuit model to calculate the actual temperature of the battery. The state of charge (SoC) values of the battery are determined based on battery energy dump and maximum capacity. The research utilizes a neural network control method to optimize control parameters considering the actual temperature and SoC values of the battery. Furthermore, an online minimum equivalent oil consumption strategy is developed to model the target function and constraint formulas for fuel consumption, which enables the determination of optimal motor torque values during equivalent fuel consumption. The torque distribution and control commands for the vehicle's power train and dynamics module are established based on the calculated engine torque and motor torque values. By considering battery behavior and controlling the power-driven system, the research aims to protect against galvanic actions and demonstrates its practical significance.

Keywords: hybrid electric vehicle, torque distribution control, environmental temperature protection battery, state of charge (SoC), neural network control, equivalent fuel consumption, power-driven system.

Introduction

With the increasing emphasis on sustainable transportation and the need to reduce greenhouse gas emissions, hybrid electric vehicles (HEVs) have gained significant attention in recent years. HEVs combine the benefits of both internal combustion engines (ICEs) and electric motors, offering improved fuel efficiency and reduced environmental impact. One crucial aspect of HEV design is the torque distribution control method and system, which determines how power is allocated between the ICE and electric motor to optimize performance and efficiency. In this research, we propose a novel torque distribution control method and system for HEVs that incorporates an environmental temperature protection battery. The integration of an environmental temperature protection battery addresses the issue of battery performance degradation caused by temperature fluctuations, ensuring reliable and efficient operation even in extreme environmental conditions.¹

The research begins by collecting ambient temperature information to determine the vehicle's location-specific environmental conditions. By utilizing a battery equivalent circuit model, the actual temperature of the battery is accurately calculated, allowing for precise control and protection mechanisms to be implemented. Additionally, the state of charge (SoC) values of the battery are calculated based on battery energy dump and maximum capacity, providing crucial information for efficient power management. To optimize the torque distribution control parameters, a neural network control method is employed. By considering the actual battery temperature and SoC values, the control method fine-tunes the power allocation between the ICE and electric motor, maximizing overall performance and efficiency. This ensures that the HEV operates in the most optimal mode based on the prevailing environmental and battery conditions.²

Furthermore, an online minimum equivalent oil consumption strategy is developed in this research. This strategy models the target function and constraint formulas for fuel

consumption, enabling the determination of optimal motor torque values during equivalent fuel consumption minimum. The torque distribution and control commands for the vehicle's power train and dynamics module are established based on the calculated engine torque and motor torque values.⁷ This approach optimizes the overall power-driven system and further enhances fuel efficiency. By incorporating the environmental temperature protection battery and implementing the proposed torque distribution control method and system, this research aims to protect against galvanic actions and enhance the performance and efficiency of HEVs. The findings of this study have significant practical significance in the field of sustainable transportation and contribute to the ongoing efforts to develop more reliable, efficient, and environmentally friendly hybrid electric vehicles.²

In the following sections, we will present the methodology used in this research, describe the torque distribution control system architecture, and present the experimental results and analysis. The results will demonstrate the effectiveness of the proposed method in achieving optimal torque distribution and enhancing the overall performance of HEVs. Additionally, the implications of this research for the automotive industry and future directions for further development and improvement will be discussed.

Related Work

Over the years, the development of hybrid vehicles has shown significant advancements compared to traditional internal combustion engine (ICE) vehicles and pure electric vehicles (EVs). Hybrid vehicles offer superior fuel economy and emission performance while still ensuring a certain driving range.¹ As the key technology for electric power-driven systems continues to evolve, the proportion of power transmission systems in hybrid vehicles, such as plug-in hybrid vehicles (PHEVs), is increasing. Consequently, batteries are gaining more attention as a power resource in the power transmission system. Energy management control has been a longstanding and important research field in hybrid vehicle studies. In the early days, energy management control used simplistic methods, with obtained insights being transformed into Boolean or fuzzy rules. While these methods are still in use today, recent research has focused on improving them. However, research in this field is still in its nascent stage in many domestic settings.² In the parallel setup, the power generated by the Internal Combustion Engine (ICE) and the electric motor is combined through mechanical linkage, as depicted in Figure 3. This arrangement drives the transmission system of the vehicle through mechanical means.

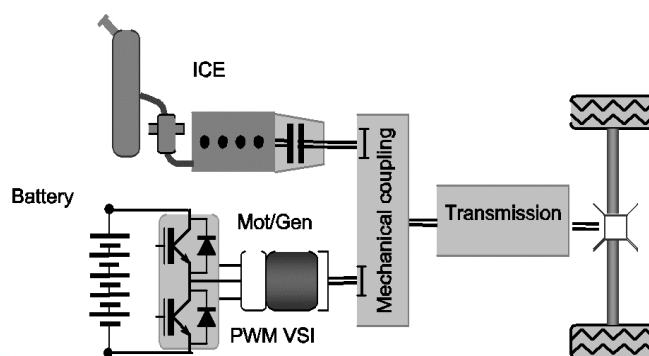

Figure 3. Parallel HEV

In 2013, researchers from Tsing-Hua University, including Leaf Dawn, analysed energy management strategies such as dynamic programming (DP), principle of minimizing power (PMP), and energy consumption minimization strategy (ECMS). Their findings demonstrated that ECMS can achieve fuel economy close to global optimization.⁴ The feasibility of implementing ECMS strategies on hybrid electric passenger cars was also demonstrated. In the same year, researchers employed fuzzy neural network methods to optimize the distribution of motor torque and devised an energy control strategy based on fuzzy logic algorithms. Similarly, in 2015, researchers proposed the optimal sorting of hybrid vehicle torque through transport information prediction. Batteries play a crucial role in hybrid electric vehicles as an important component of the power source. However, conventional research in energy management strategies often overlooks the influence of temperature and focuses solely on battery charge levels.⁶ This oversight hinders the development of effective tactics for managing battery systems under extremely high or low temperature environments, thus compromising vehicle performance and longevity.

Therefore, this research aims to address these limitations by developing a hybrid electric vehicle torque distribution control method and system that incorporates an environmental temperature protection battery.¹ By considering the impact of temperature on battery behaviour, the proposed method aims to enhance overall vehicle control and protection. This research fills a critical gap in existing studies and provides practical significance in terms of developing strategies for hybrid vehicles to operate optimally in varying temperature conditions. In the following sections, we will discuss the methodology used in this research, present the torque distribution control system architecture, and showcase experimental results and analysis.⁶ The outcomes of this study will demonstrate the effectiveness of the

proposed method in optimizing torque distribution and enhancing the performance and efficiency of hybrid electric vehicles. Additionally, the implications of this research for the automotive industry and future directions for further development and improvement will be discussed. Furthermore, by incorporating an environmental temperature protection battery into the torque distribution control method and system for hybrid electric vehicles, several key benefits can be achieved. Firstly, compared to traditional internal combustion engine vehicles, hybrid vehicles offer superior fuel economy and lower pollutant emissions while still providing a certain driving range. This makes them a more environmentally friendly option for transportation.²

As the development of electric power-driven technologies progresses, the role of the power transmission system in hybrid vehicles is becoming increasingly significant. Plug-in hybrid vehicles (PHEVs) are gaining popularity, and batteries are being recognized as a crucial power resource in the hybrid powertrain. This emphasizes the importance of efficient energy management control in maximizing the performance and efficiency of hybrid vehicles.

Research Objective

The main objective of this research is to develop a torque distribution control method and system for hybrid electric vehicles by integrating an environmental temperature protection battery. The research aims to achieve the following objectives:

1. Collect ambient temperature information to determine the vehicle's location-specific environmental conditions.
2. Calculate the actual temperature of the battery using a battery equivalent circuit model and the collected ambient temperature information.
3. Determine the state of charge (SoC) values of the battery based on battery energy dump and maximum capacity calculations.
4. Utilize a neural network control method to optimize control parameters by considering the actual battery temperature and SoC values.
5. Develop an online minimum equivalent oil consumption strategy to model the target function and constraint formulas for fuel consumption, and determine the corresponding motor torque values during equivalent fuel consumption minimum.
6. Establish torque distribution and control commands for the vehicle's power train and dynamics module based on the engine torque and motor torque values obtained in the previous step.

Hybrid Electric Vehicle Torque Distribution Control Method

The hybrid electric vehicle torque distribution control method, which incorporates an environmental temperature protection battery, involves several steps:

1. Gathering information about the ambient temperature where the vehicle is located.
2. Using the ambient temperature information and a battery equivalent circuit model to calculate the actual temperature of the battery. This calculation takes into account the battery's remaining charge and maximum capacity.
3. Utilizing a neural network control method to optimize control parameters based on the actual temperature and battery state of charge (SoC). The neural network takes two input values: x_1 (related to SoC) and x_2 (related to temperature).
4. Developing an online minimum equivalent fuel consumption strategy to model and determine the torque values for the motor and engine that result in the lowest fuel consumption.
5. Utilizing the torque distribution and control commands derived from step 4 to drive the vehicle, as determined by the powertrain and dynamics module.

Let us delve deeper into each step of the hybrid electric vehicle torque distribution control method:

1. Gathering ambient temperature information: The method starts by collecting data on the environmental temperature in the location where the vehicle is operating. This information is crucial because temperature affects the performance and efficiency of the battery.
2. Calculating battery actual temperature: Using the collected ambient temperature information and a battery equivalent circuit model, the method calculates the actual temperature of the battery. This calculation takes into account the battery's remaining charge and maximum capacity. By considering these factors, the method can accurately estimate the temperature of the battery, which is important for battery management and protection.
3. Utilizing a neural network control method: In this step, a neural network is employed to optimize control parameters based on the actual temperature and battery state of charge (SoC). The neural network takes two input values: x_1 , which is related to the battery's state of charge, and x_2 , which is

related to the battery's temperature. By processing these inputs, the neural network determines the optimal control parameters for torque distribution.

4. Developing an online minimum equivalent fuel consumption strategy: The method establishes a target function and constraint formulas for equivalent fuel consumption. It models and calculates the torque values for the engine and motor that result in the lowest fuel consumption. This strategy aims to optimize the overall efficiency of the vehicle's powertrain by intelligently distributing torque between the engine and motor.
5. Torque distribution and control commands: Finally, the torque values obtained from the previous step are used to distribute and control the torque between the engine and motor in the vehicle's powertrain. These control commands ensure that the vehicle operates efficiently and effectively, taking into account factors such as power demands, driving conditions, and the optimization goals established in the earlier steps.

By following this method, the hybrid electric vehicle can achieve improved fuel efficiency and performance. The integration of temperature protection for the battery ensures its longevity and enhances the vehicle's overall efficiency in various temperature conditions. Additionally, the optimization of torque distribution between the engine and motor helps maximize the utilization of power sources, resulting in enhanced fuel economy and reduced emissions.

Conclusion

In conclusion, the integration of an environmental temperature protection battery into the torque distribution control method and system for hybrid electric vehicles offers practical significance. By considering battery behaviour and controlling the power-driven system, this research contributes to the protection against galvanic actions. The proposed approach optimizes the utilization of the battery system by accurately estimating the battery temperature and state of charge (SoC) values. The neural network control method enhances control parameters, improving overall vehicle performance. The online minimum equivalent oil consumption strategy facilitates efficient fuel consumption and establishes torque distribution and control commands for the power-driven system. The findings of this research contribute to the advancement of hybrid electric vehicle technology, leading to more efficient and reliable transportation solutions.

Reference

1. Jinqun, Guo, et al. "Real-time energy management of fuel cell hybrid electric buses: Fuel cell engines friendly intersection speed planning." *Energy* 226 (2021): 120440.
2. Lyu, Litong, Zheng Chen, and Bin Yao. "Energy saving motion control of independent metering valves and pump combined hydraulic system." *IEEE/ASME Transactions on Mechatronics* 24.5 (2019): 1909-1920.
3. Saleeb, Hedra, et al. "Power management strategy for battery electric vehicles." *IET Electrical Systems in Transportation* 9.2 (2019): 65-74.
4. *Cyber Hierarchy Multiscale Integrated Energy Management of Intelligent Hybrid Electric Vehicles* - Y Gao, S Yang, X Wang, W Li, Q Hou, Q Cheng - *Automotive Innovation*, 2022 – Springer
5. *Energy management strategy for hybrid electric vehicle integrated with waste heat recovery system based on deep reinforcement learning* - X Wang, R Wang, GQ Shu, H Tian... - *Science China* - 2022 – Springer
6. *A comprehensive review on hybrid electric vehicles: architectures and components* - KV Singh, HO Bansal, D Singh - *Journal of Modern Transportation*, 2019 – Springer
7. *A multi-objective optimal torque distribution strategy for four in-wheel-motor drive electric vehicles* - C Lin, S Liang, J Chen, X Gao - *IEEE Access*, 2019 - ieeexplore.ieee.org