

# Stepper Motor Precise Position Control System Using DTMF Technology

Shahera S.Patel  
Department of Electronics,  
Associate Professor,  
Sardar Patel University,  
Vallabh Vidyanagar – 388 120 , Gujarat, India.  
Email : swamibhavin@gmail.com

**Abstract** : There is a great demand for stepper motor control in numerous applications such as process control in various industries, machine tools, computer peripherals, robotics etc. For many applications like laser trimming, IC bonding, and silicon processing, it is required to control the stepper motor from remote places. This paper presents the stepper motor position control using DTMF ( Dual Tone Multi frequency) technology. DTMF is a very important tool for acoustic communications because of its important advantages such as simplicity and audibility. Using a Telephone keypad, by pressing a particular key different DTMF tones have been generated which is related to the angular position signals of the stepper motor in both clockwise and anticlockwise direction. IC MT 8870 is used which decodes the received tones. The microcontroller PIC 16F628A is used to implement and process the control algorithm when DTMF tone is received. The driver used here for stepper motor is IC A3982SL. The developed system is cost effective, simple and rugged in construction. The observed experimental results shows that this system has good accuracy, repeatability and resolution.

**Keywords** : Stepper motor, DTMF technology, Position, Embedded system, Motor driver

\*\*\*\*\*

## I. INTRODUCTION

The concept of Position/Motion control has evolved since end of 18th century. Simply, position/motion control means to control the movement of the object accurately based on different physical parameters such as speed, load, distance, inertia etc. individually or a combination of these factors.

Different types of techniques [1,2] are used to control the speed of the AC motor, DC motor or Stepper motor. These methods includes digital or analog inputs, concept of Phase locked loop(PLL) etc. The common means of controlling devices are using switches. Since, last few decades use of remote control switches like-wireless remote control, Infrared remote control switch, Light activated switches have become popular for controlling various devices/loads. However, these techniques have their own limitations for short distance applications. Some techniques like IR remote control can be used effectively. In some situations the system which does not require any radiations, which is not harmful, which is most powerful and effective to use is long remote control switch. It can be used from any distance from meters to thousand kilometers using a simple telephone line or mobile phone.

Stepper motors are mainly used in measurement and control applications[3,4]. In the industries, there is a great demand and requirement for the stepper motor based positioning system. In the hazardous environment of industries particularly for chemical industries, it is very much necessary to use this type of system to carry the object or to place the object from one place to other place. Because of the inherent advantages such as fast response and positional accuracies stepper motors are used widely in numerous applications like robotics, semiconductor industries, electroplating industries, various surveillance systems, process control, inkjet printers, plotters, disk drives, machine tools, CNC machines, volumetric pumps and solar tracking systems etc. The spray painting and drying systems also uses such type of systems. Numerous features common

to all stepper motor make them ideally suitable for these types of applications.

Stepper motors are brushless. In conventional motors the most failure prone components are brushes and commutators. They create electrical arcs that are not desirable and is dangerous in some environment. Stepper motor will also not turn at a speed regardless of a load as long as the load does not exceed the torque rating of the motor. Stepper motors in open loop position move in quantified increments of steps. Holding torque characteristics is able to hold the shaft stationary. Stepper motors are basically of two types - Bipolar and Unipolar [5]. Here I have used bipolar stepper motor.

Today in this advancing world, there is an essential requirement of controlling various devices in almost all the areas/places viz. Controlling of various home appliances, public places ( Automatic traffic light signal ) control, in the industries etc. All types of controls inevitably be achieved via easily available and affordable public level interface like power line, telephone line or through internet. The media through which the objective is to be achieved depends on the device to be controlled and the placement of the device.

Now a days Embedded systems plays a very vital and important role in integrating different computations/functions which are related with it. Embedded technology is dedicated to specific task. With the advancement in the technology, the existing systems are developed to have inbuilt intelligence. The application of embedded technology i.e. use of PIC microcontroller along with DTMF technology made the system design so versatile that the system is designed with minimum hardware, minimum cost and maximum facility. Development in simplifying the programming of PIC microcontrollers made the devices more accessible.

The present paper discusses the design and development of stepper motor precise position control system. In the present scheme the DTMF ( Dual tone multi frequency ) technology

has been used for controlling the angular position of the stepper motor in both clockwise and anticlockwise direction. Facility is also provided to control the speed of the motor as and when required.

DTMF decoder (MT 8870) [6] has been used to decode the DTMF signal. The decoded signal has been read by the microcontroller PIC16F628A [7] and generates the corresponding control signal to position the stepper motor at the required angle. Driver A3982SL [8] is used to drive the stepper motor. Experimental results shows that the developed system has good accuracy, linearity and repeatability.

## II. BLOCK DIAGRAM AND METHODOLOGY :

Figure 1 shows the organization of the developed stepper motor position control system. It includes (i) Remote Section and (ii) Local Control Section.

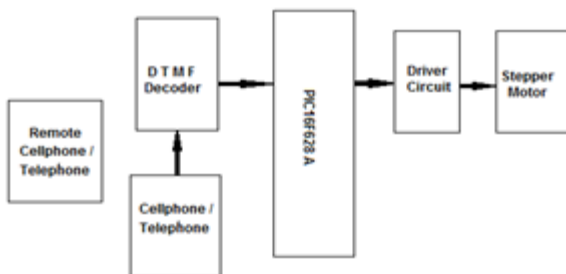

Figure 1 Block Diagram of the stepper motor position control system

Here as a media telephone is used which serves main part of this system. From the block diagram one can see that two phones have been used- one is with the user or operator side(Remote Phone) and the other in the experimental or system set up side(Local Phone) which may be placed at any distance from the user. To perform any operations through remote phone, the user needs to dial to the local telephone ( to which the experimental interfacing circuit is connected).Then the respective keys are pressed depending on the requirement to move stepper motor in either direction. This system uses Dual tone multi frequency (DTMF ) Technology of our telephone set. Every telephone have this facility. In a telephone system two types of dialing facilities are available (i) Tone Dialing mode (ii) Pulse Dialing mode. Here, the developed system works on tone dialing mode. When the user makes a call, the local system receives the call as it is always in auto receiving mode. Thus, the user and the system are connected. Now, if user presses any key on the key pad, DTMF tone is generated which corresponds to the desired angular position of the stepper motor. This DTMF signal is received by the system located at the receiving side. There it is decoded by the DTMF decoder. The DTMF decoder MT8870 decodes the DTMF into its equivalent binary digit and this binary digit is send to the microcontroller. The microcontroller is preprogrammed to take a decision for any given input and gives corresponding output signal to stepper motor driver in

order to drive the stepper motor for forward or backward direction / motion with specific speed. The power supply is designed which provides +5V and +12V DC with a 2 Ampere Current capacity. This mainly consists of Transformer, bridge rectifier, Filter, two series regulators 7805 and 7812. Transistor 2N 3055 is used to increase the current capability of Power supply.

## III. COMPLETE CIRCUIT DIAGRAM AND EXPLANATION :

Figure 2 shows the complete circuit diagram of stepper motor position control system developed using PIC microcontroller and DTMF technology.

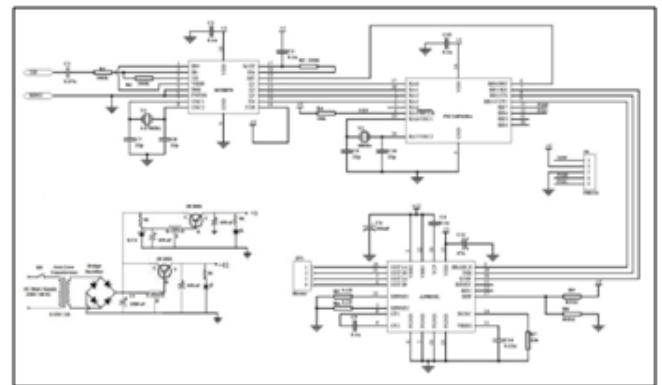

Figure 2 Circuit Diagram of stepper motor position control system

### 3.1 POWER SUPPLY :

The power supply is designed for +5V and +12 V DC output. This circuit consists of step down transformer having specifications of 0-12V /2 Amp, Positive regulator IC 7805 and 7812, diodes IN 4007, Zener Diode, LED and Resistors etc.

Here 230V/50Hz AC signal is given as the input to the primary of the transformer via switch SW1. The secondary of the transformer is given to the bridge rectifier. The output of the rectifier is applied to the regulator IC 7812 and 7805 through capacitor(2200µF/63V). The output of the regulators is connected to the

### 3.2 DTMF DECODER IC MT8870 :

The IC MT8870 is used as a DTMF ( Dual Tone Multi Frequency ) decoder. It is an 18 Pin IC available in both plastic DIP and Ceramic DIP package. It offers small size, low power consumption and high performance. It consists of band split filter section and digital decoder functions. The filter section uses switched capacitor techniques separates the high and low group tones ( frequency).The decoder uses digital counting techniques to detect and decode all 16 DTMF tone pairs into a 4-bit code, including A, B, C and D which are more commonly used in European countries. External component count is minimized by provision of an on chip differential input amplifier, clock generator and latched tri state bus interface.

It is powered by +5V DC supply. A crystal having a frequency of 3.57 MHz was connected externally between

Pin 7 (OSC 1) and Pin 8 (OSC 2) to complete the internal clock circuit. The two wires viz. TIP and RING of the phone is connected to Pin 2 and Pin 6 of decoder IC MT 8870 as shown in Figure 2.

This IC takes DTMF signal coming via telephone line and converts that signal into respective BCD number.

base of the transistor 2N3055 which increases the current capability of developed power supply. In the final output the LEDs are connected via resistors to check the status(availability) of output.

Table 1 shows the valid frequency combinations for DTMF signals with relative key pressed on keypad[9]

TABLE 1 :Relation of DTMF frequency and Key Pressed

Frequency ( Hz)	1209	1336	1477	1633
697	1	2	3	A
770	4	5	6	B
852	7	8	9	C
941	*	0	#	D

Table 2 shows the binary output(Tone output logic) for a decoded DTMF signal ( i.e Key Pressed ). If a valid frequency is found to correspond to the row and column of a DTMF tone, the decoded output as shown in Table 2 is available at pins Q1 to Q4.

TABLE 2 : Output Logic

KEY TONE	OUTPUT LOGIC			
	Q4	Q3	Q2	Q1
1	0	0	0	1
2	0	0	1	0
3	0	0	1	1
4	0	1	0	0
5	0	1	0	1
6	0	1	1	0
7	0	1	1	1
8	1	0	0	0
9	1	0	0	1
0	1	0	1	0
*	1	0	1	1
#	1	1	0	0
A	1	1	0	1
B	1	1	1	0
C	1	1	1	1
D	0	0	0	0

### 3.3 PIC CONTROLLER :

The PIC controller is the heart of the entire system. The chip used is PIC16F628A. It is an 18 pin DIP package Flash based 8-bit CMOS microcontroller. Special feature of this IC is that it has 16 I/o pins with individual direction control. The output of the DTMF decoder i.e Q1,Q2,Q3.Q4 is connected to the pins RA0,RA1,RA2,RA3 of PIC IC. The microcontroller processes and executes the software program written and generates the corresponding signals which is given to the stepper motor driver IC.

### 3.4 STEPPER MOTOR DRIVER IC A3982SL :

IC A3982SL is a DMOS stepper motor driver having built in translator for easy operation. It is designed and used to operate bipolar stepper motors in full and half step modes. Its output driving capacity is up to 35V and +2A.

The input available on pins Enable, DIR and STEP from microcontroller, rotates motor in either forward or reverse direction depending on the program written.

The main feature of this IC is there are no phase sequence tables, high frequency control lines or complex interface to program. Simply inputting the pulse on STEP input drives the motor.

The translator inputs STEP, DIR and MSI as well as the internal sequencing logic, all remain active, independent of the ENABLE input state.

### 3.5 STEPPER MOTOR:

Stepper motors can be controlled digitally in open loop mode and are used for precise positioning control. Stepper motor used here provides precision position control with an integer number of steps. ( i.e 200 steps for a resolution of 1.8 degree).

Stepper motors are stable to any step position. It enables simple, accurate control of angle of rotation which is ideally suitable for positioning systems Such as in the pick and place machines that precisely place the components on command. Stepper motors have many advantages like excellent holding torque at low speed, high simplicity since no brushes or contacts are present, low cost, high reliability and high accuracy of motion. They are normally rated in terms of their holding force. These advantages of stepper motors makes the widespread use of it in both industrial and commercial applications in almost any environment.

Stepper motor basically an electromechanical device which converts electrical pulses into discrete highly precise mechanical movements. The shaft or Spindle of a stepper motor rotates in discrete step increments when electrical command pulses are applied to it in the proper sequence.

The motor rotation has several direct relationships to these applied input pulses. The sequence of the applied pulses is directly related to the direction of motor shaft rotation. As the digital pulses increase in frequency, the speed of the step movement changes into continuous rotation. Motor shaft rotation is directly related to the frequency of the input pulses and the length of rotation is directly related to the number of input pulses applied.

A stepper motor, as the name suggests, moves one step at a time, Unlike those conventional motors, which spin continuously.

If the stepper motor commanded to move some specific number of steps, it rotates incrementally that many number of steps and stops. Because of this inherent feature it is widely used in low cost, open loop position control systems. Open loop control means no feedback information about the position is need. This eliminates the need for expensive sensing and feedback devices such as optical encoders. Motor position simply means keeping track of number of input step pulses.

IV. EXPERIMENTAL :

The user presses the keys on their telephone in a specific sequence. The DTMF decoder circuit is connected to the phone line and it interprets the DTMF signals on the line and forwards them to the main microcontroller in the form of a four bit binary number. The controller running the main firmware determines if the correct input sequence was entered by the user and interfaces with the stepper motor through the driver circuit so that the stepper motor rotates at the desired angular position as set by the user. The main system is the user interface and control system. The phone line was chosen as the method of interfacing because it has distinct advantages over other systems in communicating information from a remote or far away distance.

V. EXPERIMENTAL PROGRAMMING FLOW CHART & RESULTS :

A simple control algorithm is as shown in Fig.3 It shows that the stepper motor is used to rotate in two directions clockwise and counter clockwise mode. The motor is operated in full step drive where two windings of motor are energized at any given time. For a specific application the torque vs speed characteristics are the key for selecting correct motor and corresponding drive method.

In application where operations are performed at low or moderate speeds and load torque is stable open loop driver / controller is performed more since it requires easy and simple control algorithm[10]

\* One step angle = 1.8o

\* No. of Steps = 1 Rotation of revolution of Stepper Motor / Step Angle

$$= 360o / 1.8o$$

$$= 200$$

The design of stepper motor controller is very important for high precision positioning and smooth rotation operation.

VI. CONCLUSION :

The developed system is user friendly. Can be used to control the stepper motors from the remote place and still keeps the privacy and it restricts the access to the unauthorized user. This type of motor will hold its position firmly at a given step providing a relatively high holding torque.

VII. FUTURE SCOPE :

According to the recent trends one can use GSM for control of the Motors/other devices from any remote places with the help of GSM one can receive the system status and information via SMS.

With implementation of feedback and little change in Hardware and software this design concept can be used in Lift control and Robotic as well as many other remote applications.

REFERENCES :

[1] Muhammad Ali Mazidi & Mazidi “ The 8051 Microcontroller & Embedded Systems”, Pearson Education  
 [2] D.Manojkumar, P.Mathankumar, E.Saranya and S.Pavithradevi, Mobile controlled robot using DTMF technology for Industrial application, International Journal of Electronics Engineering Research,2010,2(3),P.P:349-355  
 [3] T.Kenjo and A.Sugawara,”Stepping Motors and their Microprocessor controls,2<sup>nd</sup> Edition,Oxford University Press,1994.  
 [4] Opamp and Linear Integrated Circuits by R.A.Gayakwad  
 [5] Stepper Motor Reference Design by Silicon Labs  
 [6] MT8870- MITEL,ISO<sup>2</sup>-CMOS Integrated DTMF receiver  
 [7] PIC16F628A - Microchip Technology Inc.,2007 Ds 40044F-P.1,2  
 [8] Driver A3982 – Allegro Microsystems Inc.  
 [9][http://www.homeautomation.wikidot.com/dtmf\\_decoder](http://www.homeautomation.wikidot.com/dtmf_decoder)  
 [10] Zoonubiya Ali and R.V.Kshirsagar International Journal of Engineering Research,Vol.2,No.2,(2010) P: 219 -228

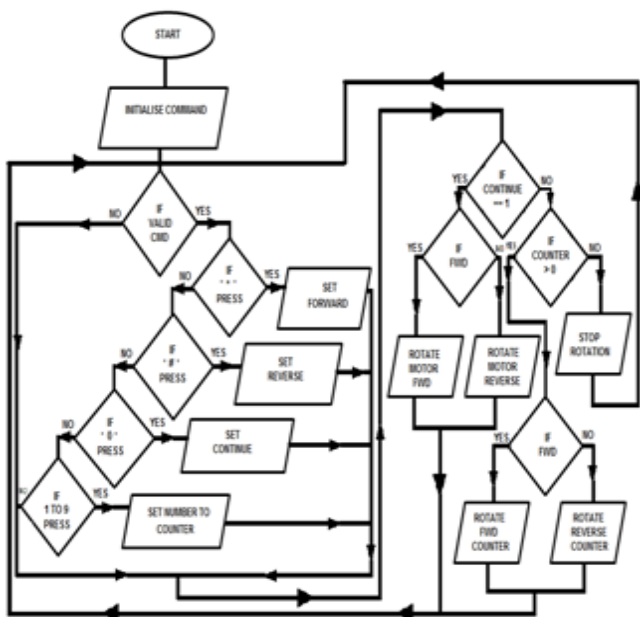

Fig.3 Flow Chart of Stepper Motor Control