

## Solar Powered Gardener

Varun Dhawan<sup>1</sup>, Anindu Bose<sup>2</sup>, Vishal Danve<sup>3</sup>,  
Department of Electronics Engineering  
KC College of Engineering and Management Studies, Thane 400 603, India  
varundhawan49@gmail.com<sup>1</sup>  
anindubose@gmail.com<sup>2</sup>  
vishaldanve4@gmail.com<sup>3</sup>

**Abstract** — This paper states an idea to use the abundantly available solar power in a very unique method for reducing human efforts in a Garden/Park. This concept explains how technology can be used to reduce human efforts as well as to efficiently utilize renewable sources of energy. A detailed documentation of a Solar Powered Gardner has been made.

**Keywords** — *Out-door localization, Solar, Grass-cutter, Atmega16, energy conservation, Water Sprinkler.*

\*\*\*\*\*

### I. INTRODUCTION

Solar Energy is one of the most abundantly available forms of energy exposed to humans. A large part of this energy gets wasted. Efficient use of Solar Energy can significantly reduce the scarcity of our day to day energy requirement for present as well as future generations. An example of how solar energy can be harvested by implementing it with the available technology is shown with an example of solar powered gardener.

The Solar Powered Gardner is an automated grass cutting robotic vehicle powered by solar energy. It is designed such that it can avoid the obstacles automatically, while carrying out its operations of grass cutting and/or water sprinkling. The system uses 12V batteries to power the robotic assembly. A Solar Panel is used to charge these batteries. An Atmega16 controller is used as the brain of the system. The grass cutter, water sprinkler motors and the wheel motors are interfaced to the ATmega16 microcontroller that controls the working of all the motors. Detection of objects is a very important factor for safety of the assembly as well as human safety, so the micro controller is interfaced with a sensor unit that carries out object detection. On detection of object or obstacle a preprogrammed action is taken by the controller as per the conditions sensed by the sensor.

### II. RELATED WORK

In the field of solar grass cutter, different types of work have been done so far. Various such research paper display how the available technology can be used to harvest solar energy.

“AUTOMATIC GRASS CUTTING MACHINE BY USING PHOTOVOLTAIC SOURCE AND MOTOR SPEED CONTROL”, " Mr. P. PUGAZHENDIRAN", "Mr. A. BHARANEETH", & "N. MOHAMEDNIZAR"[1]. The paper basically focuses on the proposal for reduce the manpower and usage of electricity. Maximum power point tracking technique is used to improve the efficiency of the solar panel. The DC to DC buck boost converter helps to step up the DC voltage from the photovoltaic panel and store the DC voltage in a battery. It is an automated system for the purpose of grass cutting. The source is drive from the solar energy by using photovoltaic panels. The DC-DC converter is used to convert the low level DC voltage into the high level DC voltage. High level DC voltage helps to operate the whole system. The system control is done by the microcontroller. Automation is achieved by

using sensors and microcontrollers. Wheels and cutting operations are done using dc motors. DC battery is utilized for powering and standby mode operation of the system.

Bing-Min Shiu and Chun-Liang Lin "Design of an autonomous lawn mower with optimal route planning", [5]. This paper develops an optimal path planning scheme for autonomous lawnmowers, including the minimum working time, the minimum energy consumption mode and the mixed operation mode. A global positioning system (GPS) is equipped with the mowing path planning system which provides real-time position of the lawnmower. An algorithm for multitask operation is also presented.

### III. METHODOLOGY

The designing of such a system uses interfacing of various electronic components together. The implemented system uses a microcontroller as it control unit, a sensor microcontroller interface is required and a motor to microcontroller interface is required along with a LCD panel and a Bluetooth module interfaced to the controller. All this is powered by two 6 volts batteries in parallel connection providing a 12 volt output, these batteries are charged by the Solar panel.

The components used are an Atmega16 Microcontroller, a 16\*2 LCD panel, Bluetooth module, IR Sensor Units, DC motors & a 12 volt 10 Watt Solar panel.

#### A. Block Diagram

The block diagram of the system can be shown as below, it shows all the required main elements and their interfaces.

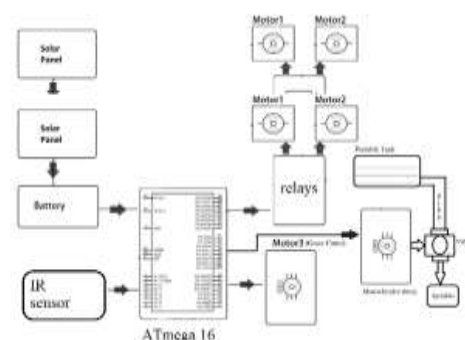

Fig 3.1 Block Diagram of the system

- *ATmega16*

It has High-performance, Low-power AVR® 8-bit Microcontroller. It is Advanced RISC Architecture with 131 Powerful Instructions – Most Single-clock Cycle Execution 32 x 8 General Purpose Working Registers. It shows Fully Static Operation, Up to 16 MIPS. Throughput at 16 MHz , On-chip 2-cycle Multiplier. Non-volatile Program and Data Memories 16K Bytes of In-System Self-Programmable Flash, Endurance: 10,000 Write/Erase Cycles, Optional Boot Code Section with Independent Lock Bits. In-System Programming by On-chip Boot Program True Read-While-Write Operation, 512 Bytes EEPROM.

- *Power Supply*

The designed power supply is made up of solar panel, which gives 12V 10W as output. This 12V output is capable of running motors, relays, blades and pumps. All the other circuitry is given a regulated voltage of +5V.

- *LCD*

Liquid crystal Display (LCD) displays temperature of the measured element, which is calculated by the microcontroller. CMOS technology makes the device ideal for application in hand held, portable and other battery instruction with low power consumption.

**GENERAL SPECIFICATION:**

1. Drive method: 1/16 duty cycle
2. Display size: 16 character \* 2 lines
3. Character structure: 5\*8 dots.
4. Display data RAM: 80 characters (80\*8 bits)
5. Character generate ROM: 192 characters
6. Character generate RAM: 8 characters (64\*8 bits)
7. Internal automatic reset circuit at power ON.
8. Built in oscillator circuit.

- *Solar panel:*

12V 10Watt Solar Panel

Heavy Duty Solar Panel with excellent power output[2]. Ideal for use as a basic charger or to power small motors, radios, etc.

**Features**

AP Monocrystalline Blue Solar Cell

Peak Voltage (Vmp): 12V

Open Circuit Voltage (Voc): 6.0V - 6.8V

Peak Current (Imp): 400mA

Short Circuit Current (Isc): 400mA - 432mA

Maximum Power (Pmax): 2.5W

Dimensions: 165mm x 120mm x 3.0mm (LxWxD)

- *Voltage regulator:*

LM7805 Series Voltage Regulators are used. A voltage regulator is an electrical regulator designed to automatically maintain a constant voltage level. It may use an electromechanical mechanism, or passive or active electronic components. Depending on the design, it may be used to regulate one or more AC or DC voltages. Any difference is amplified and used to control the regulation element.

- *DC Motors:*

Here the dc motors used are 12V permanent magnet DC motors. 4 Motors are used to move the bot, per side two motors are used in parallel combination, so they work as a single unit. Another additional motor is placed at the front of the frame; this motor has blades as its propeller so that grass is cut when this motor turns on. A motor is interfaced with the micro controller and is connected with the tank and nozzle so as to carry out the sprinkling action when required.

**B. Circuit Diagram & Working**

The proposed architecture depicts communication between sensors and microcontroller resulting into decision making of the controller device as programmed by the user for each case.

The below given circuit diagram representation shows the actual interface between components and pin connections implemented for the system.

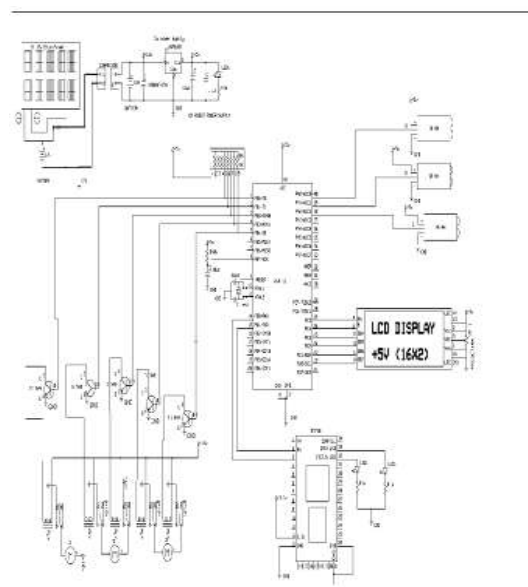

Fig 3.2 Circuit diagram of the system

When a signal arrives at the controller the required action is done accordingly to satisfy that particular signal. Controller is programmed in this case to move forward or reverse or to take turns on object detection by the IR sensors. It also carries out grass cutting action or water sprinkling action as set mode response by the user on the Bluetooth control module.

Here are the steps the user takes place for functioning of the bot.

- When the power is turned on controller is set to initial position by the reset pulse
- Command is received for setting of mode as grass cutter or water sprinkler.
- Execution of process is done according to selected mode.
- If obstruction is received as a signal by IR sensor, direction of bot is changed. Modules and System Requirements Bluetooth module is required to pair a Bluetooth application with controller here HC05 is used [3][6]. Also a LCD display module is used to debug or display messages on the screen when necessary.

C. Program Flow Diagram

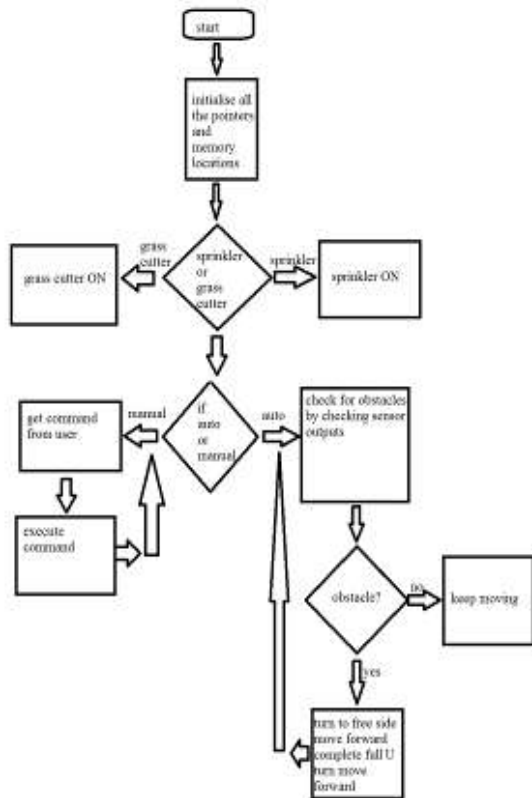

Fig 3.3 Program flowchart

Program execution starts with initializing all the memory location and pointers. All the sensor modules are initialized. Commands are checked for grass cutter or sprinkler. If sprinkler is selected, sprinkler motor is started, if grass cutter action is selected grass cutter blade starts functioning. Both grass cutter and water sprinkler can also be used at a time. Under auto or manual selection condition selection, for auto made object detection signals are monitored from the sensor units and commands are executed as per the program. For manual mode commands are accepted from the external Bluetooth control module[4][7].

IV. RESULT & OBSERVATION

The proposed paper is a detailed sum of an implemented project architecture which executes and satisfies the requirement of designing a solar powered gardner. The implemented hardware gives the following specifications

Grass cutter motor	=	1000rpm
Wheel motor	=	60rpm
Wheel diameter	=	10.8cm
Wheel circumference	=	$\pi * 10.8 = 34\text{cm}$
Distance covered in one rotation	=	34cm
I.e. one rotation per second		
Bluetooth module range		20 meter
IR sensor Range		0 cm - 15 cm

Fig 4.1 system specifications

Pictures of the implemented system are given below



Fig 4.2 Top view of the implemented system



Fig 4.3 Front view of the system



Fig 4.4 sprinkler nozzle

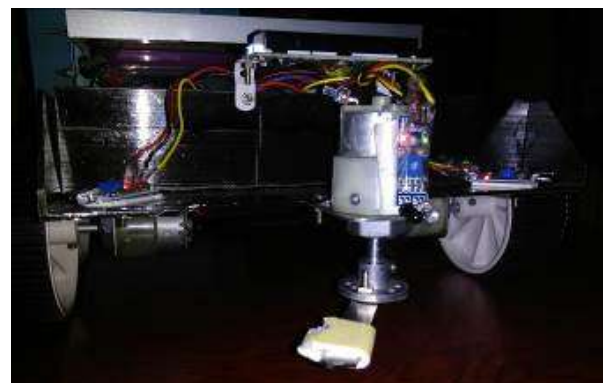

Fig 4.5 grass cutter blade



Fig 4.6 water pump

## V. CONCLUSION & FUTURE SCOPE

This paper has presented the design and development of the solar powered gardener which is based on object detection based of IR sensor. The above implementation was an effort to understand how microcontroller and IR sensor in interface with solar panel as power source and motors to drive the assembly along with a motor to cut grass and a pump to sprinkle water can be used to function as a lawn care taker. To implement more number of operations and to get high throughput higher versions of controller can be selected. In future IR sensors can be replaced by IP cam and other program devices which will detect boundaries and correct its path more accurately. A fixed pattern for every session can be fed by user by appropriate programming.

## REFERENCE

- [1] "AUTOMATIC GRASS CUTTING MACHINE BY USING PHOTOVOLTAIC SOURCE AND MOTOR SPEED CONTROL", " Mr. P. PUGAZHENDIRAN", "Mr. A. BHARANEETH", & "N. MOHAMEDNIZAR" Associate professor /HOD OF EEE1 Senior Assistant professor2 UG scholar3
- [2] "Photophysics of Bio-Inspired Solar Energy Conversion", by Robert Schmitz " ARIZONA STATE UNIVERSITY May 2014"
- [3] "Design and implementation of autonomous Lawn-Mower Robot controller", "[Wasif, M.](#) ;Dept. of Electr. Eng., Univ. of Gujrat, Gujrat Print ISBN: 978-1-4577-0769-8
- [4] Jason Smith, Scott Campbell and Jade Morton "Design and Implementation of a Control Algorithm For an Autonomous Lawnmower", *Circuits and Systems, 48th Midwest Symposium on Digital Object Identifier*, vol. 1, pp.456 -459
- [5] Bing-Min Shiu and Chun-Liang Lin "Design of an autonomous lawn mower with optimal route planning", *Industrial Technology, 2008. ICIT 2008. IEEE International Conference on*, pp.21 -24
- [6] Mohammad Baloch, Taj and Timothy Thien Ching Kae "Design and modelling a prototype of a robotic lawn mower", *Information Technology, 2008. ITSIM 2008. International Symposium on*, vol. 4, pp.26 -28
- [7] Guo-Shing Huang, Hsiung-Cheng Lin, Keng-Chih Lin and Shih-Hung Kao "Intelligent auto-saving energy robotic lawn mower", *Systems Man and Cybernetics (SMC), 2010 IEEE International Conference on*, pp.10 -13