

# An Efficient Grid Network-Based Photovoltaic Wind Generator with Load Side Converter

**Lata Bala Awale**

Assistant professor,

Department of Electrical Engineering,

Government College of Engineering Chandrapur

[lata.dupare@gmail.com](mailto:lata.dupare@gmail.com)

**Abstract:** The paper's main goal is to produce high-quality electricity using renewable energy sources; in this case, wind power systems are taken into account. Generally speaking, there are two ways to run a system: independent and grid linked. In this study, two distinct control schemes—the generator side control scheme and the load side control scheme—are used to demonstrate how to control a freestanding system. They aid in controlling the power supplied to the load and the output voltage levels even in the event of input side changes. The control approach is tested using the MATLAB environment. Control is used to modify the frequency and amplitude of the inverter voltage at varying wind speeds. The Maximum Power Point Tracking (MPPT) is the main focus of this article's application of Generalised Predictive Control to a wind power conversion system. The RST regulator obtained GPC is the controller that was designed.

**Keywords:** Grid, BES, PLL, RSC, and GSC in MATLAB.

## 1. INTRODUCTION

Distributed generation (DG) system [5] has emerged due to the de-regulation in the electric markets. These units comprise both renewable and non-renewable sources. As there is an increase in the awareness for environmental preservation and the drive to reduce greenhouse gas emissions, there has been a significant shift towards renewable energy sources [4], leading most people to associate the acronym DG with such. Among those, wind energy, being clean, reliable and commercially competitive, has been one of the most popular choices. There are many wind energy conversions systems (WECS) in use and many new systems are being planned. According to the Global Wind Energy Council (GWEC), the total capacity of wind power operating in the world reached 194.4 GW in 2010, an increase of 22.5 % from 159.2 GW in 2009. In Canada alone, the installed capacity is 4009 MW in 2010, an increase of 17% from 2009. In coming years With many government incentives across most of its provinces, it is expected that wind power installation will experience steady growth. As Wind power cannot be predicted like the other resources it has a different conversion system. The main reasons for the contrast nature of the conversion system are (1)the construction of WECS, which most commonly use

power electronics-based converters, resulting in the application of different topologies, (2) the unpredictable nature of wind power, which is alternating and undecided, and (3) the change from a passive distribution network into an active one with multiple energy sources and bidirectional power flow. Due to these factors with wind power, it interacts differently with the power system network. The challenging part of this is the dependency of the injected power on the wind speed. Therefore ,fluctuations in wind velocity can affect branch power flows, bus voltages, reactive power injections, system balancing, frequency control, power system dynamics and stability. In addition, it can also affect the power quality by introducing harmonics and flicker, due to the Switching actions of the power electronics converters and can also affect protection systems due to the increase in fault levels. As above mentioned, different grid codes have been developed for wind power integration so as to fulfill technical requirements such as frequency and voltage control, active and reactive power management and fast response during transient and dynamic situations. Different topologies for the conversion system have been developed keeping in view the technical and economical reasons. Variablespeed WECS are the preferred option due to superior power extraction, controllable output

power, quick response under transient and dynamic situations, reduced mechanical stress and acoustical noise. Variable-speed WECS can be a p p l i e d t o Doubly-Fed Induction Generators (DFIGs or Type-3 generators) or synchronous generators and full-scale converters (also referred to as Type-4 generators). While DFIGs have gained popularity in recent years, Type-4 generators have been gradually capturing the market. So it is necessary to reunite each topology for the WECS to get better benefits. The interaction of wind turbines with electrical power systems is becoming more significant. With the rapid increase in the number of WECS in power system, the effects of wind power on the grid [3] need to be fully understood and properly investigated. As the size of WECS is becoming larger and the penetration of wind power in power system is increasing, the inherent problems of fixed-speed WECS become more and more pronounced, especially in areas with relatively weak supply grid [1]. To overcome these problems and to comply with the grid-code connection requirements, the trend in modern WECS technology is to apply variable-speed concepts. With the developments in power electronics converters, which are used to connect wind turbines to the grid, variable speed wind energy systems are becoming common. The main advantages of variable-speed WECS are increased power capture, improved system efficiency, improved power quality with less flicker, reduced mechanical stress, reduced fatigue, and reduced acoustic noise. Additionally, the presence of power converters in wind turbines also provides high potential control capabilities for both large modern wind turbines and wind farms to fulfil the high technical demands imposed by the grid operators. The main features of variable-speed WECS are controllable active and reactive power (frequency and voltage control) [2], quick response under transient and dynamic power system situations, influence on network stability and improved power quality. Their disadvantages include losses in power electronic elements and increased cost. Variable-speed WECS are designed to achieve maximum aerodynamic efficiency over a wide range of wind speeds. It is possible to continuously adapt (increase or decrease) the Rotational speed of WECS according to the wind speed. As the wind turbine operates at variable rotational speed, the electrical frequency of the generator varies and must therefore be decoupled from the frequency of the grid. This is achieved by using a power electronic converter system, between induction or synchronous generator and the grid. The power converter decouples the network electrical frequency from the rotor mechanical

frequency enabling variable speed operation of the wind turbine. Variable-speed operation can be achieved by using any suitable combination of generator (synchronous or asynchronous) and power electronics interface, as it will be explained in the following subsections. There are three main configurations of variable-speed converters. They are the limited variable-speed, the variable-speed with partial-scale frequency converter, and the variable-speed with full-scale frequency converter. These configurations can use any of the power-control mechanisms, namely stall, pitch or active stall control. As mentioned earlier, the pitch control mechanism is the most widely used. Limited Variable-Speed (The Type-2 WECS) This concept uses a wound rotor induction generator (WRIG), which is directly connected to the grid. A capacitor bank is used for reactive power compensation and a soft-starter is employed for smoother grid connection. A unique feature of this concept is that it has a variable rotor resistance, which can be changed to control the slip. This way power output in the system is controlled, typical speed range being 0-10% above synchronous speed.

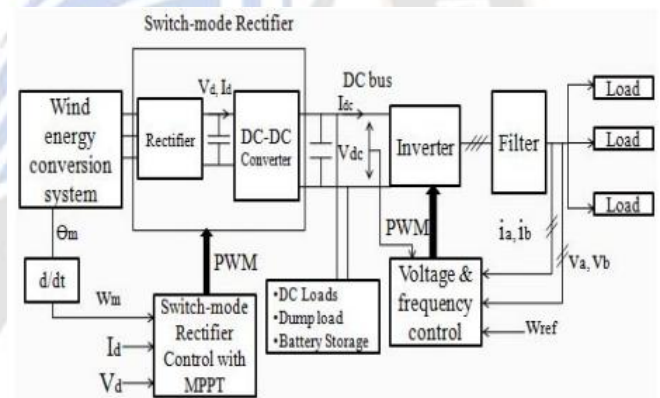

Fig.1. Block diagram.

## 2 LITERATURES SERVEY

With the increasing concern about environment, many people look for clean, renewable and inexhaustible energy resources [1-3]. Wind energy can be seen as sustainable attractive source of electricity. Rising from 6100 Megawatts of generating capacity in 1996 to 369597 Megawatts at the end of 2014, wind energy has been the source that has the highest growth of electrical energy from renewable sources in the world [4]. Standalone wind energy conversion systems are electric energy alternative sources for isolated area. They usually supplies air conditioning mechanical loads, ventilation and water pumps [5]. For remote communities, the generator voltage stability is the main concern for any regulation scheme [6, 7]. Batteries are

critical elements for an autonomous power supply system to keep the balance between the generated power and the power requested by the load [8]. The battery bank is attached to the DC bus via a buck-boost converter. The control purpose of the DC converter is maintaining the DC voltage at a consistent level. During the last twenty years, GPC strategy has benefited from a growing concern in numerous control applications [9]. Compared to conventional control methods, GPC is an efficient method for applications that request high performances with good properties in both time and frequency domains [10]. GPC algorithms are largely used because of his prominent characteristics like stability and robustness [9, 11]. In Ref. [12], Hui et al has established a neural network controller to estimate the wind velocity. They used a PI for extracting the maximum of energy from the wind. Kamel Ouari et al developed a Nonlinear Generalized Predictive Controller with nonlinear Observer for a DFIG based variable speed wind turbine [13]. QIU et al present a wind energy system equipped with PMSG, but the use of the diode rectifier decrease the efficiency of the control system [14]. In [15], a Generalized Predictive RST regulator is used for controlling the output voltage of wound rotor synchronous generator. In this study, a generalized predictive controller is suggested for the PMSG speed control. The results of simulation are presented to show the advantage of the proposed control strategy.

**RECOMMENDED SYSTEM:**

The block diagram shows the wind energy conversion system and the rectifier, DC-DC converter, inverter system to convert dc supply into ac and filters are required for the elimination of unwanted content in the inverter output, to supply the pure sine voltage to load centre. Load side inverter contains IGBT's as switches and the frequency and potential difference deviations are restricted within the limits by the operations switches which are used in the inverter. To extract the maximum power from the variable speed wind turbine and transfer the power to load then the duty cycle of the switch in dc-dc converter is controlled by this controller in Fig. 2. Standalone wind system.

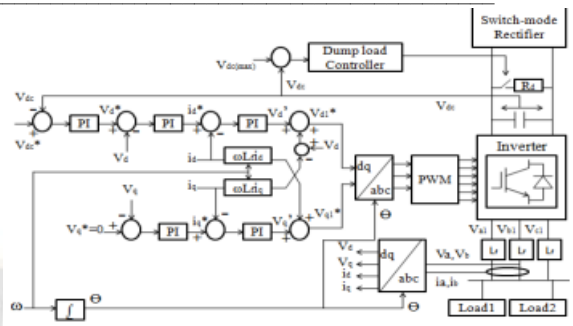

**3. OVER VIEW OF PROPOSED SYSTEM**

The paper deals with renewable energy system is not connected to any grid system, simply works in standalone mode. In renewable energy system air flow is variable and load is also fluctuating continuously it leads to variations in the Vout and it is controlled by the output voltage controller. The VDC is stabilized by providing dc link controller.

$$\begin{bmatrix} v_a \\ v_b \\ v_c \end{bmatrix} = R_f \begin{bmatrix} i_a \\ i_b \\ i_c \end{bmatrix} + L_f \frac{d}{dx} \begin{bmatrix} i_a \\ i_b \\ i_c \end{bmatrix} + \begin{bmatrix} v_{a1} \\ v_{b1} \\ v_{c1} \end{bmatrix}$$

**Voltage transformation in rotating reference frame**

$$V_d = v_{d1} - R_f i_d - L_f \frac{di_d}{dx} + \omega L_f i_q$$

$$V_q = v_{q1} - R_f i_q - L_f \frac{di_q}{dx} - \omega L_f i_d \quad (1)$$

**Three phase instantaneous power is written as**

$$P(t) = v_a i_a + v_b i_b + v_c i_c = [v_a \ v_b \ v_c] [i_a \ i_b \ i_c]' \quad (2)$$

**Transformation of powers are expressed as**

$$P = \frac{3}{2} (v_d i_d + v_q i_q) \quad (3)$$

In Variable Speed wind frameworks, power gadgets converters keep the rotor speed and the network recurrence separated. In factor speed wind turbines matrix recurrence not influenced the rotor speed and it goes about as free. Hence it is clear that the rotor speed always depends on the variations of input power. The input power is slightly higher when it is compared with output power of the wind turbine and which gives the stability as well as delivered the power in soft manner to the grid system. The force nature of these breeze vitality frameworks is greatly improved contrasted with their fixed speed partners. Variable wind speed turbines are operated in large scale speed range by maintaining the tip speed ratio optimum. The primary use of these turbines, it captures the higher energy and the limitation only its control is complex in nature.

#### 4. SIMULATION RESULTS:

Acceleration of the wind is variable here, the wind flow varies from 10m/s to 12m/s to 9m/s and then back to 10m/s as shown in figure 4(a), 4(b). The control strategy is clearly observed at source side in figure 5(a), 5(b) it is observed that the mechanical torque and reference torque are in similar manner i.e., following the reference torque. The figure 5(a), 5(b) shows that Idc & reference currents and measured dc currents are in same path and maximum power is extracted by regulating TT as shown in figure 6(a) and 6(b) shows the output dc power. The electric loads are dynamic in nature and the wind system is not constant power supplier, depends purely on the wind available in the atmosphere. Figure 4 shows the constant/fixed wind speed condition, the response of RMS Voltage, RMS Currents in per unit system along with voltage across the dc link, load and frequency at load center and “m” is the modulation index. Case ii: In this case the load changes are consider (dynamic load) it varies from 1 p.u. to 0.5 p.u. and back to full load conditions in a specified time period i.e., varies from 1 p.u. to 0.5 p.u. of load changes  $t=4s$  until time changes to  $t=5s$ . The figure 5 shows the variations in instantaneous voltages and currents, RMS voltages and currents.

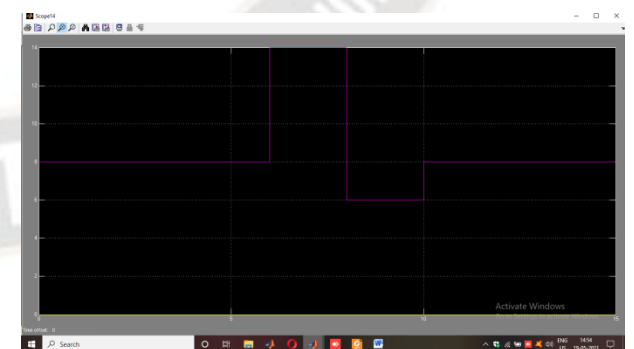
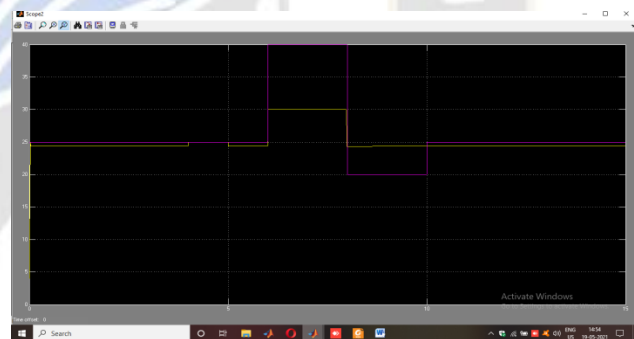
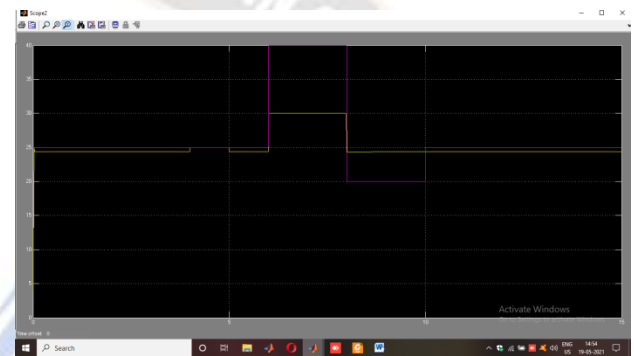
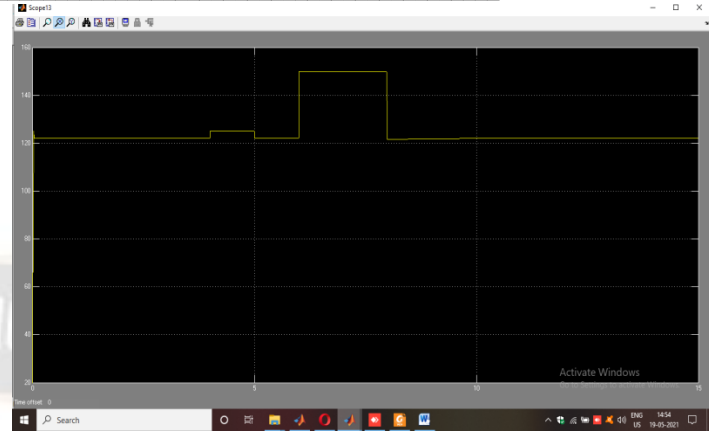
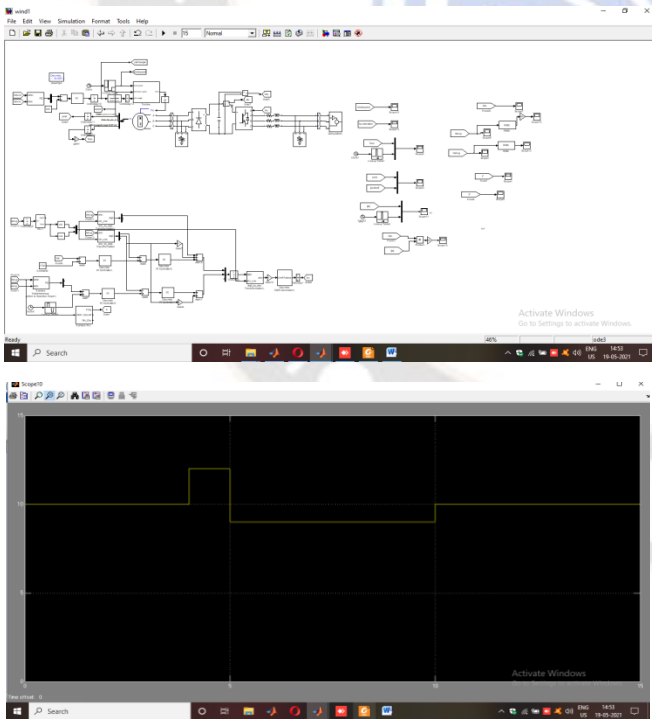

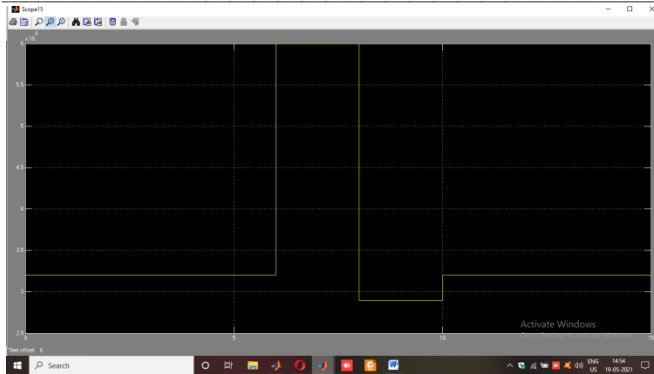

**Fig: 4** change in the wind speed when subjected to sudden change (a) Flow of wind (m/s). (b) Acceleration of the generator (red/sec). (c) TT and TREF. (d) TGET and TREF. (e) IDC & Irked. (f) Output of PDC.

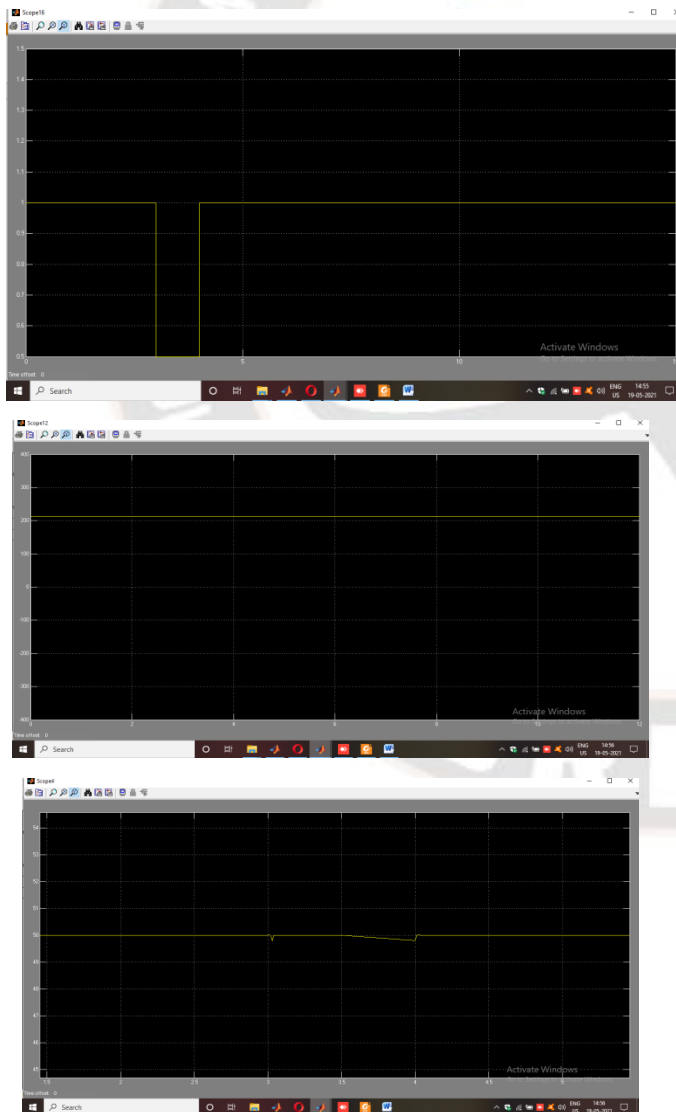

**Fig: 5** load variations from 1 to 0.5 put. And from 0.5 to 1 put. (a) Potential difference of DC link. (b) Voltage across the load (c) current flow in load center. (d) FL. (e) Depth of Modulation.

### CONCLUSION:

In order to stabilise the voltage and frequency of the generator and load side converters for both fluctuations in input air flow and load uncertainty, generator and load side control techniques are put into practice. The load characteristics, including torque, current, frequency, and modulation index, are shown in the figure. The load side control technique ensures that these parameters are well-regulated within acceptable bounds.

### REFERENCES

- [1] Louar FATEH, Ouari AHMED, Omeiri AMAR, Djellad ABDELHAK, Bouras LAKHDAR, Modeling and control of a permanent magnet synchronous generator dedicated to standalone wind energy conversion system, *Frontiers in energy Springer*,2016.
- [2] M. F. ELMorshedy, S. M. Allam, Ahmed I. A. shobair and Essam M. Rashad, "Voltage and Frequency Control of a Standalone Wind-Energy Conversion System Based on PMSG," in *proc. IEEE Power Eng. Annu. Meeting*, 2015.
- [3] Aditya Venkataraman, Ali Maswood, Nirnaya Sarangan, Ooi H.P. Gabriel "An Efficient UPF Rectifier for a Stand-Alone Wind Energy Conversion System," *IEEE Trans. on industry applications*, vol. 50, NO.2, Marsh/April. 2014
- [4] Y. Izumi, A. Pratap, K. Uchida, A. Uehara, T. Senjyu, A. Yona, "A control method for maximum power point tracking of a PMSGbased WECS using online parameter identification of wind turbine," *Proc. Of the IEEE 9th International Conf. on Power Electronics and Drives Systems*, Singapore, 5–8 Dec. 2011, pp. 1125–1130.

[5] M. Singh, A. Chandra, B. Singh, "Sensorless power maximization of PMSG based isolated wind-battery hybrid system using adaptive neuro-fuzzy controller," IEEE Ind. Appl. Soc. Annual Meeting, 2010, pp. 1-6.

[6] S. Müller, M. Deicke, and R. W. De Doncker, "Doubly fed induction generator system for wind turbines," IEEE Ind. Appl. Mag., vol. 8, no. 3, pp. 26–33, May 2002.

[7] Nishad Menddis, Kashem M. Muttaqi, Sarath Perera "Management of Battery-Supercapacitor Hybrid Energy Storage and Synchronous Condenser for Isolated Operation of PMSG Based Variable-speed wind Turbine Generating Systems"IEEE Trans. ON SMART GRID, vol. 5, NO.2, MARCH 2014

[8] M. R. Dubois, "Optimized permanent magnet generator topologies for direct-drive wind turbines" Ph.D. dissertation, Delft Univ. Technol., Delft, The Netherlands, 2004.

[9]A. Grauers, "Design of direct-driven permanent-magnet generators for wind turbines" Ph.D. dissertation, Chalmers Univ. Technol., Göteborg, Sweden, 1996.

[10] E. Spooner, P. Gordon, J. R. Bumby, and C. D. French, "Lightweight ironless-stator PMgenerators for direct-drive wind turbines," Inst. Electr. Eng. Proc. Elect. Power Appl., vol. 152, no. 1, pp. 17–26, Jan. 2005.

