

Single Phase Transformer less Grid Connected PV Inverter: A Review

Carmaline Joel Anthony
Department of Electrical Engineering
Priyadarshini College Of Engineering &
Technology, Nagpur
Nagpur, India
carmaline1607@gmail.com

S.Gotekar
Department of Electrical Engineering
Priyadarshini College Of Engineering &
Technology, Nagpur
Nagpur, India
p_somkuwar@yahoo.com

S. P. Muley
Department of Electrical Engineering
Priyadarshini College Of Engineering &
Technology, Nagpur
Nagpur, India
shubhada_muley@rediffmail.com

Abstract—This paper focuses on advancement and development of power converter technology in PV systems generally used in grid connected residential setup. Grid-connected PV systems play a key role in power systems, which are connected by power electronics converters. The conventional inverters with transformers connected in PV grid-tied generation system are now being replaced by transformerless inverter. Thus this paper gives an overview on inverter technologies available for connecting solar photovoltaic (PV) modules to a single-phase utility grid. Various transformerless inverter topologies are presented, compared, against demands, lifetime and operations. Finally, a topology is picked out and suggested to be most suitable for single PV module used in residential application.

Keywords—*photovoltaic systems; power converters; transformerless; single-phase.*

I. INTRODUCTION

Nowadays, the invention and development of new energy sources are being continuously enhanced which in turn makes renewable energy sources to become a more important contributor to the total energy consumed in the world. Traditional power generations that are on a basic of fossil fuel resource are considered to be unsustainable in long term national strategies. This has been one of the main driving forces for an increasing installation of renewable energies like wind power, solar Photovoltaic (PV) power, hydropower, biomass power, geothermal power, and ocean power, etc. into the public grids [1], [2]. Among the major renewable energy resources, photovoltaic (PV) power supplied to the utility grid is gaining more and more visibility, while the world's power demand is increasing [3]. Not many PV systems have as yet been unified into the grid due to the relatively high cost as compared with other traditional energy sources. This paper starts with an examination of the total renewable energy installed capacity in India and the year-wise targets of grid connected rooftop solar system. This is followed by the discussion on power converter technology for PV system, demands for the inverters, the requirement of grid-tied system, the PV modules, and the operators. Next follows an overview of some existing power inverter topologies for interfacing PV modules to the grid. The approaches are further discussed and evaluated in order to recognize the most suitable topologies for residential grid-tied PV inverters, and, finally, a conclusion is given.

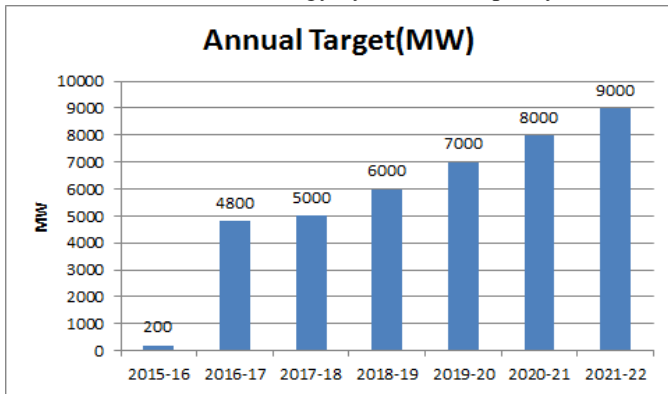
II. TOTAL RENEWABLE ENERGY INSTALLED CAPACITY

India is fourth largest energy consumer in the World, which is mainly due to its population growth and economic development. The Government of India proposed to launch its Jawaharlal Nehru National Solar Mission under the National Action Plan on Climate change with plans to generate 1,000MW to 20,000 MW grid-based solar power and 2,000 MW of off-grid solar power [3]. The Mission aims to achieve grid parity (electricity delivered at the same cost and quality as that delivered on the grid) by 2020. The Table(1) below gives the detail of the total renewable energy by installed capacity in India as of 30 Nov 2015, MNRE India[4].

The Ministry of New and Renewable Energy has released the year-wise, state-wise target for rooftop Solar. According to revised target, government has raised the solar targets to 100 GW by 2022, and rooftop solar will contribute 40 GW to the revised target. Fig(1) shows the year wise target of solar rooftop power generation in MW as on 30th June 2015, MNRE India.

Source	Total Installed Capacity (MW)
Wind Power	24759.32
Solar Power(SPV)	4684.74
Small Hydro Power	4161.9
Biomass Power	4550.55
Waste to Power	127.08
Total	38,283.59

Table(1): Renewable energy by installed capacity in India



Fig(1): Year-wise Target for grid connected rooftop solar system.

III. Power converter technology for PV system

Photovoltaic (PV) power generation has become one of the major approach to the use of solar energy and the distribution generation system are normally interfaced to the grid through power electronic converters or inverter [5] as shown in Fig(3), each of the grid-connected concepts consists of series of paralleled PV panels or strings, and they are configured by a couple of power electronics converters (DC-DC converters and DCAC inverters) in accordance to the output voltage of the PV panels as well as the power rating. [6].

A. Grid-tied photovoltaic inverter

PV systems are modular by nature and can therefore be implanted in a wide power range. There are mainly four configuration concepts[2],[3],[6],[7] available to organize and transfer the PV power to the grid, as it is shown in Table(2).

The main norms that grid connected inverters have to comply with are:

- Total Harmonic Distortion (THD) and individual harmonic current levels
- Power factor (PF)
- Level of injected DC current
- Voltage and frequency range for normal operation
- Detection of islanding operation (islanding or non-islanding functions)
- Automatic reconnection and synchronizing
- Grounding of the system

B. Requirement of Grid-tied system

The PV system connected to the grid requires two distinct tasks, one of which is to ensure that the solar panels are operated at MPP and the other is that the injected current must be sinusoidal which has to satisfy some specific standards[8]. Grid-connected solar PV system feed solar energy directly into the building loads without battery storage. Surplus energy if

any is exported to the grid and shortfall, if any, is imported from the grid.

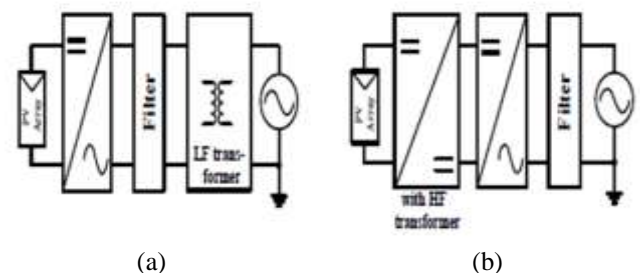
C. System components and Capacities.

A grid-tied solar PV system consists of the following components.

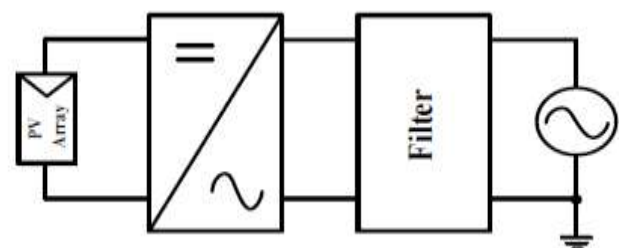
- Solar PV array
- Solar Grid inverter
- Filter
- Protection devices
- Cables

The size of a solar PV system in India depends on the 90% energy consumption of the building and the shade-free rooftop area available. The recommended inverter capacity in KW shall be in a range of 95% - 110% of the solar PV capacity. The PV generates DC voltage; thus, it requires a converter to convert into a voltage of corresponding amplitude at the main frequency for feeding it into utility grid.

The inverters role in grid-tied PV system is to be the interface between two energy sources: the PV module and the utility grid. Since the role of the inverter is to convert DC power of PV module into AC power for integration into utility grid, it is responsible for power quality that needs to be satisfied by the requirement of different standards. Depending on the galvanic isolation between the PV module and the grid, the PV inverter can be categorized as isolated or non-isolated. The galvanic isolation between the PV module and the grid can be observed by using a line frequency transformer or a high frequency transformer that adjusts converter DC voltage[9],[10].



Fig(2): Grid connected PV system inverter (a)low frequency (LF) transformer (b) high frequency (HF) transformer



Fig(3): Grid connected PV system with Transformerless inverter.

Converters including a transformer either use a low-frequency transformer or a high-frequency transformer. Low-frequency transformers are identified as poor components due to increased size, weight, and prize. Converters with high-frequency transformers include various power stages and are understood as pretty complex. A higher efficiency, smaller size & weight and a lower price for the inverter is possible in case the transformer is omitted. Transformerless concept is advantageous as it increases the efficiencies of the system which reaches up to 97%– 98%, which is highly attractive for distributed power generator systems[11].

To increase the efficiency and reduce the size and cost of grid connected power systems, the most competent remedy is to remove the isolation transformer. But it leads to the inception of common mode leakage current as the parasitic capacitance is present between the PV panel and the ground. The common-mode leakage current flows via parasitic capacitance of the panel to the system which is not desired to be energized. It causes personal safety issues, degradation in panels, system losses, reduces the grid-connected current quality and induces the severe conducted and radiated electromagnetic interference [13]. To overcome the this drawback of the transformerless inverter, bipolar and unipolar sinusoidal pulsewidth modulation is employed with a combination of half-bridge or full-bridge inverter [9],[10],[11].

Another major concern related to the system is that the inverters must also be able to detect an islanding situation, and take appropriate measures so as to avoid damage to persons and equipment [14]. Islanding is a condition when the energy resource continues to supply to the load even when the utility grid has been removed on purpose, by accident, or by damage. In other words, islanding mode of operation causes the grid to be disconnected from the distribution generation [15].

IV. INVERTER TOPOLOGIES

Inverters can have one or more stages according to the levels of power conversion. Generally single-phase systems are most commonly used in the private sector or residential application. The majority of such PV systems can have up to 5KW and are roof mounted with a fixed tilt and a southward orientation [12]. Taking into consideration the presented scenario, highly efficient single-phase inverter topologies that will most likely reach a high level of efficiency at low cost are the ones established by a single-stage transformerless inverter. Fig(4) gives a detailed layout of the different transformerless inverter topologies[24][25].

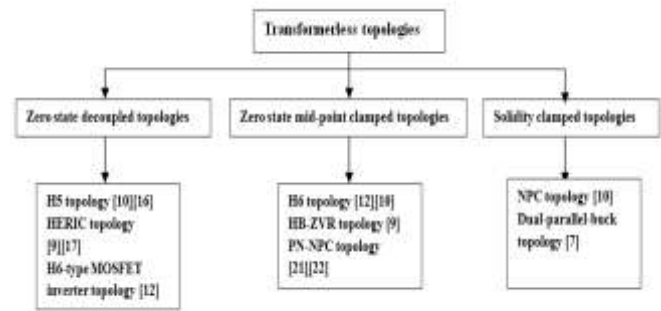


Fig 4: Transformerless inverter topologies

4.1 Zero state decoupled topologies

4.1.1 H5 topology

This inverter basically consists of a full-bridge along with an extra switch, as shown in Fig 4(a). This type of topology is similar to the already presented single-phase chopping and, hence, have some of its advantages in common. This inverter topology applies unipolar-SPWM to operate this inverter with three-level output voltage. During the positive half cycle current flows through S1, S4, S5 and switches S4 and S5 are commutated with switching frequency. The zero voltage vectors are achieved when S4 and S5 are turned off and the freewheeling current flows through S1 and the body-diode of S3. In the negative half cycle, S5 and S2 are switched with switching frequency and the freewheeling current flows through S3 and the body-diode of S1. One of the major drawback of this topology are the higher conduction losses due to the series association of three switches during the active phase, and operation with reactive power is possible only with modified switching strategy characterized by increased losses.

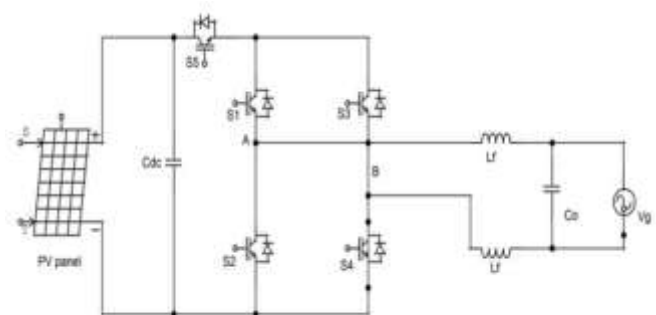


Fig 4(a) : H5 inverter topology

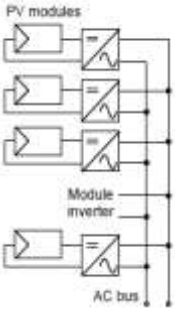
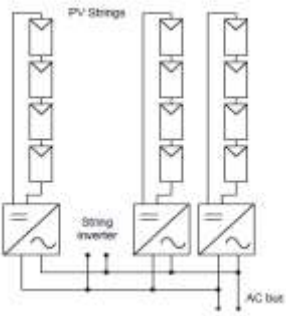
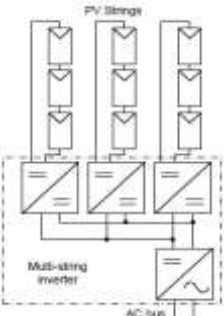
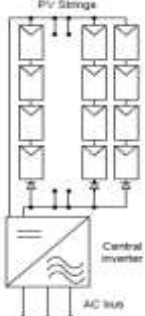
Type	Module	String	Multi-string	Central
Circuit Topology				
DC bus	Low voltage, low current	High Voltage, low current	Comparatively Higher voltage and current	High voltage, High current
Power rating	approx 300 W	1KW- 10KW	30KW	50KW
Advantages	reduction of installation costs through elimination of dc cabling, flexible expansion, system design with different types of modules, and practically no maximum power point tracking mismatch losses.	lower installation costs and reduced conduction losses due to higher input-voltage levels, higher overall efficiency, separate MPPT for each string.	higher overall efficiency than multi-central inverters, separate MPPT for each string, they are usually three phase.	Higher reliability and simplicity of installation, central inverters are usually three phase.
Limitations	high specific cost that relies on mass production to reach competitiveness, lower electrical efficiency in comparison with larger converters, and, difficult maintenance and harsh ambient conditions that require a highly reliable design	High voltage level present a potential safety hazard	More inverter connections, requires more distributed space to mount inverter.	Higher power losses, mismatch losses, inflexible design, high current harmonics, lower power quality.

Table (2): Comparison of inverter configuration concept

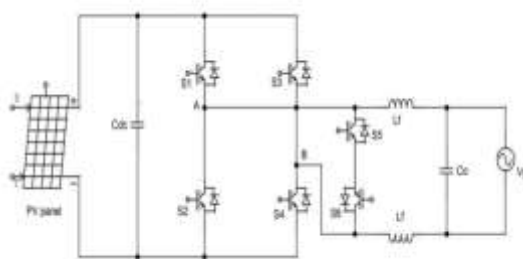


Fig 4(b) : HERIC inverter topology

4.1.2 HERIC topology

This topology is as shown in fig 4(b), to obtain higher efficiency it combines the advantages of three-level output voltage given by the unipolar PWM, but still there exists the common-mode behavior as in case of the bipolar PWM, as in [9][17] the Highly Efficient and Reliable Inverter Concept (HERIC). The bidirectional switch consists of two insulated-gate bipolar transistors (IGBTs) and two diodes (S5 and S6). During the positive half cycle of the load voltage, S6 is switched on and is used during the freewheeling period of S1 and S4. On the other hand, during the negative half cycle, S5 is switched on and is used during the freewheeling period of S2 and S3. This way, the zero-voltage state is accomplished by short-circuiting the output of the inverter, during which period the PV is separated from the grid, because S1–S4 or S2–S3 are turned off. The output voltage of the inverter has three levels and the load current ripple is very small, although, in this case, the frequency of the current is equal to the switching

frequency. The inverter generates no common-mode voltage; therefore, the leakage current through the parasitic capacitance of the PV would be very small as compared to other topology.

4.1.3 Improved H6 topology

A H6-type MOSFET inverter topology is proposed in [18] where the low effective IGBT's are replaced by MOSFET as shown in Fig6(c). For this topology unipolar-SPWM is implemented with three-level output voltage. During the positive half cycle of grid current, the switch S1 and S4 are turned off, the freewheeling current flows through S5 and D1. During the negative half cycle, switch S2 and S3 are turned off and current flows through S6 and D2. The indicated peak efficiency and European efficiency of H6-type MOSFET inverter on 300 W prototype circuit with 180 V DC bus voltage and 30 kHz operating frequency were 98.3% and 98.1%, respectively [18,19]. The grid current flows through three switches during the active mode; as a result, conduction losses still prevail in the system. Another concern is that the anti-parallel diodes of MOSFETs will be activated if a phase shift occurs between the inverter output voltage and current. As a result, the system is less dependable due to the low reverse recovery issues of MOSFETs anti-parallel diode.

A. 4.2 Zero state mid-point clamped topologies

5.2.1 H6 topology

This topology consists of six switches and two diodes as illustrated in fig 4(c). Replacing the switch S5 of the H5 inverter with two split switches S5 and S6 into two phase legs and adding two freewheeling diodes D5 and D6 for freewheeling current flows, the H6 topology was proposed in [12]. During positive half cycle switch S1 and S4 are on, S5 and S6 commutate at the switching frequency together with switch S5 and S6. During negative half cycle S2 and S3 are on and switch S5 and S6 commutate at switching frequency together with switch S5 and S6. The switching losses of this topology is lower than those of the bipolar PWM full bridge and can be to some extent similar to those of unipolar PWM full bridge [26]. The H6 inverter can also be implemented using MOSFETs for the line frequency as switching devices, eliminating the use of less efficient IGBTs. The fixed voltage conduction losses of the IGBTs used in the H5 inverter are avoided in the H6 inverter topology which in turn improves efficiency; however, there are higher conduction losses due to the three series-connected switches in the current path during active phases. Another disadvantage noted in the H6 inverter topology is that when the inverter output voltage and current has a phase shift the MOSFET body diodes may be activated. This can effect in body diode reverse-recovery issues and decrease the reliability of the system.

4.2.2 HB-ZVR topology

Full bridge inverter topology with AC bypass has been proposed in [12] called H-Bridge Zero Voltage Rectifier (HB-ZVR) topology, where the short circuited output voltage is clamped to the mid-point of the DC bus during freewheeling period through a diode rectifier and one bidirectional switch. In order to oppose the lower DC link capacitor from short circuiting, an extra diode is added as shown in Fig4(e). It can be stated that the principle of operation of HB-ZVR inverter

topology is very similar to the HERIC topology. The gate pulse of switch S5 during the positive half-wave is the opposite of the gate pulse of switches S1 and S4, with a small dead time to neglect short circuit of the grid [12]. During the negative half wave, switch S5 is controlled using the opposite gate pulse of switches S2 and S3 and creates zero-voltage state by short-circuiting the output of the inverter and clamping them to the mid-point of the DC bus. The clamping function of this topology has been achieved using diode D5, which allows one-directional clamping only if the freewheeling path has a higher potential than the mid-point voltage of the DC link. As a result, CM voltage fluctuation could be monitored when the reverse condition is occurred. Disadvantage of this inverter topology is the necessity of dead time which increases the distortion of the output current.

4.2.3 PN-NPC topology

The neutral point clamped (NPC) topology is an excellent research for the grid-tied PV system [20,21]. There are basically two kinds of switching cells, the positive neutral-point clamped cell and the negative neutral-point clamped cell to develop NPC topology, called as the PN-NPC topology which is illustrated in Fig.4(f). The working principle of this topology is similar to that of the H6 topology. During freewheeling period, the short circuited output voltage is directly clamped to the half of DC input voltage through S7 and S8. Consequently, the CM voltage is kept constant at $VPV/2$ and the leakage current is also low.

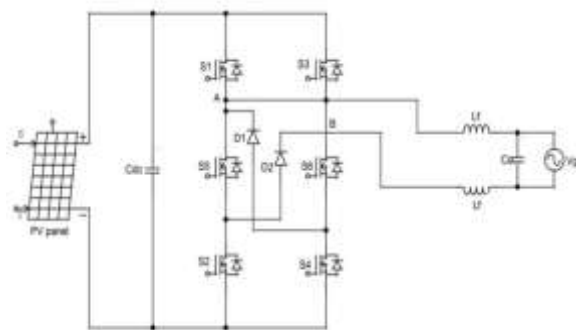


Fig4(c) : H6- MOSFET topology

The PN-NPC inverter has three-level output voltage with magnificent DM characteristics. The main drawback of the PN-NPC topology is the use of higher number of switches which leads to more complexity. Another drawback is that the inductor current flows through four switches in the positive half cycle of grid current; thus, higher conduction losses are also present in this topology

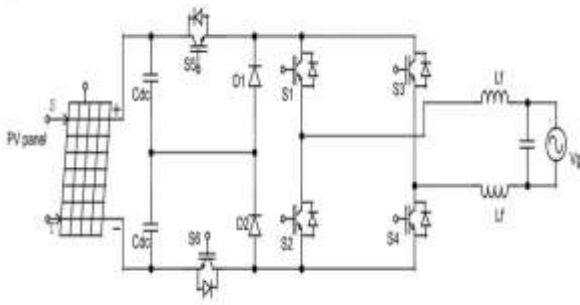


Fig4(d): H6 topology

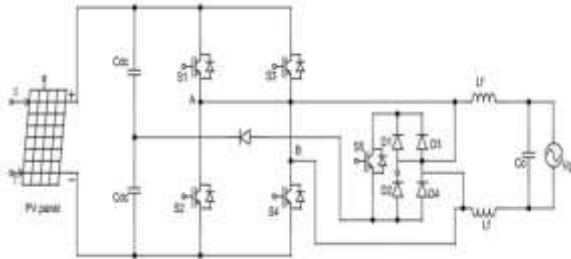


Fig 4(e): HB-ZVR inverter topologies

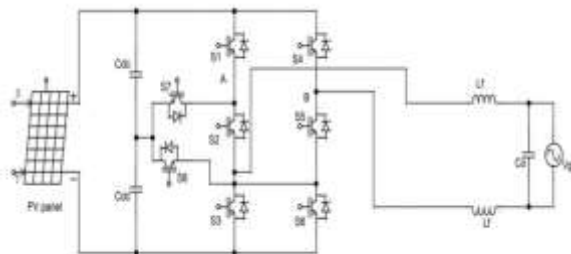


Fig 4(f): PN-NPC inverter topology

4.3.2 Dual-parallel-buck topology

A solidly clamped transformerless topology in [7] called dual-parallel-buck converter as shown in Fig4(h). This topology has been derived to get reverse power flow. The negative output of PV module is directly connected to the neutral of the inverter during the positive half cycle as well as to the phase during the negative half cycle. Thus, high frequency CM voltage oscillation is minimized, resulting in low leakage current[22]. The inductor current flows through two switches in the active mode; thus the conduction loss is reduced. The reported maximum efficiency and European efficiency for a 4.5 kW prototype circuit with 16 kHz switching frequency were 99% and 98.8%, respectively. The main disadvantage of this topology is that the grid will be short circuit if no dead time is present between switches S3 and S4 through which the grid is directly connected. At the moment of zero crossing, a dead time of 500 mS has been added that may increase the distortion of the output current and reduce the reliability of the topology

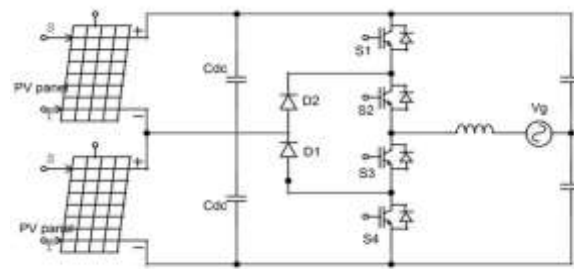


Fig4(g) : NPC inverter topology

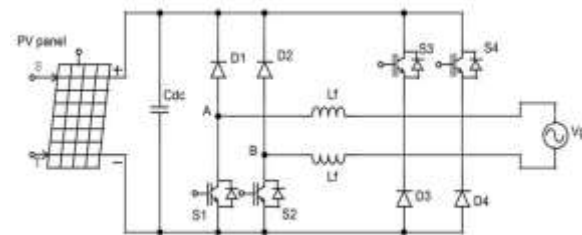


Fig4(h) : DLL inverter topology

B. 4.3 Solidity clamped topologies

4.3.1 NPC three-level VSI

The neutral point clamped half-bridge topology is the multilevel-based topology for single phase operation. This type of topology is mostly used in high power motor drive applications. In recent times, many research work have been done and some are still going on and lately an NPC topology has been proposed in [20] for single phase operation to be used in the grid-tied PV system. It consists of four switches S1–S4 and two diodes D1–D2 to clamp the mid-point voltage as illustrated in Fig4(g). The use of the clamping diodes is to provide the freewheeling path for the output current during the freewheeling mode, resulting in the 0V output state [20]. The principle of operation of this topology is very similar to that of the half-bridge topology, but the efficiency is greater and current ripple is less[23]. Moreover, the high frequency CM voltage is kept constant; thus in return the leakage current is minimized. The major drawback of this topology is the necessity of higher input voltage 800 V if compared with the FB topology. Therefore, it requires high capacity bank of capacitor, which is another additional disadvantage of this topology

CONCLUSION

Transformerless PV grid-connected inverters for residential applications are the devices on the market with the fastest growth and development. Transformerless inverters offer better efficiency, compared to those inverters that have a galvanic isolation. But, in case the transformer is omitted, the generated common-mode behavior of the inverter topology greatly influences the ground leakage current through the parasitic capacitance of the PV array. This paper has reviewed the different transformerless PV inverter topologies presently available. The principle of operation, advantages and disadvantage of different inverter topologies have been discussed. For residential system the power required is relatively low as compared to industrial system and other system. Thus the most suitable inverter topology would be H6

topology which has two input capacitor, 400 VDC, six switches, two diodes, transistor voltage and number of switches , 600 (2) 1200 (4), the leakage current is also very low and the efficiency is 97.4%

REFERENCES

- [1] Vivek Panwar, Tarlochan Kaur, "Overview of Renewable Energy Resources of India" , International Journal of Advanced Research in Electrical, Electronics and Instrumentation Engineering, Vol. 3, Issue 2, February 2014
- [2] Blaabjerg, Frede; Ma, Ke; Yang, Yongheng, "Power Electronics for Renewable Energy Systems - Status and Trends", 8th International Conference on Integrated Power Systems 2014
- [3] Soeren Baekhoej Kjaer, John K. Pedersen, and Frede Blaabjerg, "A Review of Single-Phase Grid-Connected Inverters for Photovoltaic Modules." IEEE Transactions On Industry Applications, Vol. 41, No. 5, September/October 2005.
- [4] The Ministry of New and Renewable Energy (MNRE), "Selection of new grid connected solar PV power projects", www.mnre.gov.in
- [5] Ministry of New and Renewable Energy (MNRE), " State-wise and year-wise targets for installation of 40,000 MWp Grid Connected solar rooftop syatem., www.mnre.gov.in
- [6] Kerekes, Tamas, "Analysis and Modeling of Transformerless Photovoltaic Inverter Systems", Universitet: Institut for Energiteknik, Aalborg Universitet. 2009
- [7] Samuel Vasconcelos Araújo, Peter Zacharias, and Regine Mallwitz, "Highly Efficient Single-Phase Transformerless Inverters for Grid-Connected Photovoltaic Systems" IEEE Transactions ON Industrial Electronics, Vol. 57, No. 9, September 2010
- [8] Stefanos Saridakis, Eftichios Koutroulis and Frede Blaabjerg "Optimal Design of Modern Transformerless PV Inverter Topologies" IEEE Transactions On Energy Conversion, Vol. 28, no. 2, June 2013.
- [9] Tamás Kerekes, Member, IEEE, Remus Teodorescu, Senior Member, IEEE, Pedro Rodríguez, Member, IEEE, Gerardo Vázquez, Student Member, IEEE, and Emiliano Aldabas, Member, IEEE "A New High-Efficiency Single-Phase Transformerless PV Inverter Topology" IEEE Transactions On Industrial Electronics, Vol. 58, no. 1, January 2011.
- [10] Bo Yang, Wuhua Li, Member, IEEE, Yunjie Gu, Wenfeng Cui, and Xiangning He, Fellow, IEEE "Improved Transformerless Inverter With Common-Mode Leakage Current Elimination for a Photovoltaic Grid-Connected Power System" IEEE Transactions On Power Electronics, Vol. 27, No. 2, February 2012
- [11] O´scar Lo´pez, Member, IEEE, Francisco D. Freijedo, Member, IEEE, Alejandro G. Yepes, Student Member, IEEE, Pablo Fern´andez-Comesa˜na, Student Member, IEEE, Jano Malvar, Student Member, IEEE, Remus Teodorescu, Senior Member, IEEE, and Jes´us Doval-Gandoy, Member, IEEE "Eliminating Ground Current in a Transformerless Photovoltaic Application" IEEE Transactions On Energy Conversion, Vol. 25, No. 1, March 2010
- [12] Roberto González, Jesús López, Pablo Sanchis, and Luis Marroyo "Transformerless Inverter for Single-Phase Photovoltaic Systems", IEEE Transactions On Power Electronics, Vol. 22, No. 2, March 2007.
- [13] T. Kerekes, R. Teodorescu, U. Borup, "Transformerless Photovoltaic Inverters Connected to the Grid", Aalborg University , Denmark.
- [14] Tarak Salmi, Mounir Bouzguenda, Adel Gastli, Ahmed Masmoudi "Transformerless microinverter for photovoltaic systems" International Journal Of Energy And Environment Volume 3, Issue 4, 2012 pp.639-650
- [15] Almas Hossain Mollah1, Prof. G KPanda2, Prof. P KSaha3, "Single Phase Grid-Connected Inverter for Photovoltaic System with Maximum Power Point Tracking", International Journal Of Innovative Research In Science, Engineering And Technology, Volume 3, SPECIAL ISSUE 1, February 2014.
- [16] Huafeng Xiao, and Shaojun Xie, "Leakage Current Analytical Model and Application in Single-Phase Transformerless Photovoltaic Grid-Connected Inverter" IEEE Transactions On Electromagnetic Compatibility, Vol. 52, No. 4, November 2010
- [17] Schmidt D, Siedle D, Ketterer J. Inverter for transforming a DC voltage into an AC current or an AC voltage, ed: EP Patent 1,369,985; 2009.
- [18] YuW, LaiJ-S, QianH, HutchensC.High-efficiency MOSFET inverter with H6-type configuration for photovoltaic nonisolated AC-module applications. IEEE TransPowerElectron2011;26:1253–60.
- [19] WensongY, Jih-ShengL, HaoQ, HutchensC, JianhuiZ, LisiG, et al.High-efficiency inverter with H6-type configuration for photovoltaic non-isolated ac module applications.In :Proceedings of the twenty-fifth annual IEEE applied power electronics conference and exposition (APEC);2010.p.1056–61.
- [20] Gonzalez R , GubiaE , LopezJ, MarroyoL.Transformerless single-phase multi- level-based photovoltaic inverter. IEEE Trans Ind Electron 2008 ;55 : 2694–702.
- [21] RodriguezJ, BernetS, SteimerPK, LizamaE. A survey on neutral-point-clamped inverters.IEEE Trans Ind Electron 2010;57:2219–30.
- [22] Bin Gu, Student, Jason Dominic, Jih-Sheng Lai, Chien-Liang Chen, Thomas LaBella, and Baifeng Chen, "High Reliability and Efficiency Single-Phase Transformerless Inverter for Grid-Connected Photovoltaic Systems" IEEE Transactions On Power Electronics, Vol. 28, No. 5, May 2013 2235 .
- [23] Salvador Alepuz, Sergio Busquets-Monge, Josep Bordonau, Javier Gago, David González, and Josep Balcells, "Interfacing Renewable Energy Sources to the Utility Grid Using a Three-Level Inverter", IEEE Transactions On Industrial Electronics, Vol. 53, No. 5, October 2006
- [24] Martina Calais' Johanna, Myrzik2 Ted Spooner, Vassilios G. Agelidis4, "Inverters for Single-phase Grid Connected Photovoltaic Systems - An Overview", International Journal. Of Advanced Research In Electrical, Electronics And Instrumentation Engineering Vol. 4, Issue 2, February 2015.
- [25] Yongheng Yang, Frede Blaabjerg, "Overview of Single-Phase Grid-Connected Photovoltaic Systems" UEMP, Electric Power Components and Systems, 2015
- [26] N.Shivthej .G.Arjun Shekar, "Photo Voltaic Grid-Tied Inverters using H6 Transformer less Full-Bridge", Dept of Power Electronics and Electrical Drives, C.R.E.C, Tirupati, Andhra Pradesh, India1 Dept of Electrical & Electronics Engg. C.R.E.C, Tirupati, Andhra Pradesh, India